



0073-1-6048
24661

**ABB ibus® EIB
Combi actuator 6173 AG-101-500
GJB 000 6151 A0138
with 4-gang binary input**

for use as:

4-gang switching actuator

2x2-gang shutter actuator

2-gang switching-/1x2-fach-shutter actuator

Operating instructions
Only for qualified electricians with EIB training



Contents and Scope of Supply

Contents of this Operating Instructions Manual

Important Information	3
Device Overview	4
Positioning of the Plug-In Jumpers and Device Function	5
Device Description	6
Technical Data	8
Internal Links, Configurations, Sensor Inputs	10
Examples of Wiring	12
Wiring Diagrams	15
Installation	17
Commissioning	20

Scope of Supply

- Housing with combi actuator
- Operating Instructions Manual
- Screw/plug-in terminals
 - 1 terminal 2-gang (green)
 - 3 terminals 4-gang (green)
 - 3 terminals 5-gang (green)
 - 1 terminal 6-gang (grey)
 - 1 Bus terminal (green)
- 3 cable entries
(closed, for unused housing inlets)

Important Information

General

Detailed descriptions of the application programs and documents to assist planning are available for planning and configuring bus devices in an ABB ibus[®], EIB system.

You can obtain these documents from ABB.

Standards and regulations

For the planning and erection of electrical installations, the relevant standards, guidelines, regulations and provisions of that country have to be observed in which the installation is to be erected and operated.

Please check in any case if these standards and regulations permit polyphase operation.

If polyphase operation is permitted, such a wiring system requires an **all-pole disconnection** of all load and control lines since there is a **danger to life**.

For installation work

Work on the ABB ibus[®] EIB bus may only be performed by qualified electricians.

The laying and connection of bus and power cables and of the application devices must be effected in accordance with the relevant national DIN-VDE guidelines as well as with those contained in the EIB manual of the ZVEI/ZVEH.

The applicable safety requirements (e.g. accident prevention regulations, "law governing technical equipment") must also be adhered to when working on connected operating media and installations.

The plug-in jumpers I and II (see Fig. 1) may be withdrawn **straight** to the top or inserted only by means of suited tools (such as, e.g., flat pliers).

Device operation

- Do not operate the combi actuator 6173 AG-101-500 (hereinafter referred to as combi actuator) outside its specified technical data. **Observe the maximum load of the inputs and outputs of the combi actuator!**
- The device is equipped with 4 binary inputs for conventional switches or pushbuttons. These binary inputs can be optionally operated with an interrogation voltage of 24 V ~ (50 Hz), 24 V - or 230 V ~ (50 Hz). **A mixed operation with an interrogation voltage of 24 V and 230 V is not permitted.**
- **A parallel switching of the outputs of one or several devices is not permitted.**
- When operating the device as a shutter actuator, **only one shutter motor may be connected to each output.**
- **The switching of three-phase loads (e.g., motors) is forbidden.**
- In dry locations, the device can be installed on walls as well as on ceilings.
- **In damp locations, only a vertical installation on walls is permitted** (water drain on the bottom).

Device Overview

On the following page, you will find explanations referring to Fig. 1 and to the jumper locations for the various configurations of the combi actuator.

Fig. 1 Combi Actuator

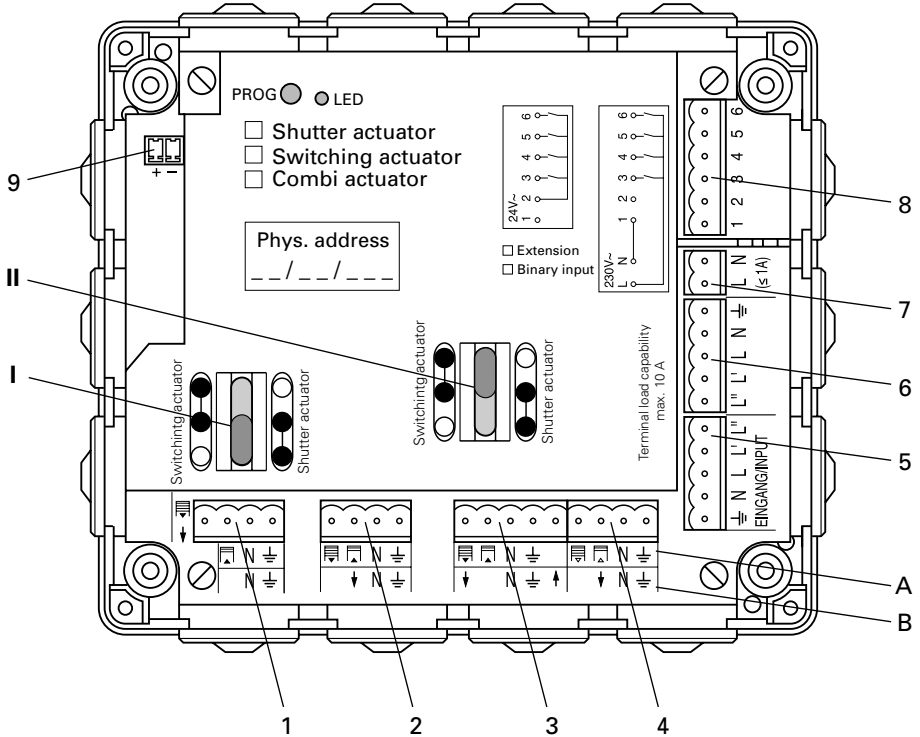

CAUTION

Plug-in jumpers (Pos. I and II) must be neither inserted nor withdrawn while the device is neergized!

The screw/plug-in terminals (Pos. 1 to 8) must be neither withdrawn nor inserted while the device is energized!

Also unused screw/plug-in terminals must be clipped on (shock protection).

When operating the device as a shutter actuator, only one shutter motor may be connected to each of the respective outputs!

A mixed operation with 24 V and 230 V at the sensor inputs is not permitted!

Positioning of the Plug-In Jumpers and Device Function

Explanations ref. to figure 1

Pos. I : plug-in jumper for outputs 1/2

Pos. II : plug-in jumper for outputs 3/4

Pos. A and Pos. B:

The upper row A reflects the terminal assignment for configuration as a shutter output, whereas the lower row B shows the terminal assignment for configuration as a switching output.

Pos. 1 : output 1

A : DOWN - UP - N - \perp

B : \downarrow - free - N - \perp

Pos. 2 : output 2

A : DOWN - UP - N - \perp

B : free - \downarrow - N - \perp

Pos. 3 : output 3

A : DOWN - UP - N - \perp - free

B : \downarrow - free - N - \perp - \uparrow *)

*) : Input for power supply L

Pos. 4 : output 4

A : DOWN - UP - N - \perp

B : free - \downarrow - N - \perp

Pos. 5 : system voltage input

Pos. 6 : overcoupling terminal for looping-through the 230 V supply voltage

Pos. 7 : optional power supply (230 V ~) for the interrogation contacts

Pos. 8 : binary inputs 1 - 4

Pos. 9 : Bus connection

Positioning of the plug-in jumpers and device function

Fig. 2a: Location and positioning of the plug-in jumpers when the device is operated as a 4-gang switching actuator (application V 1.1)

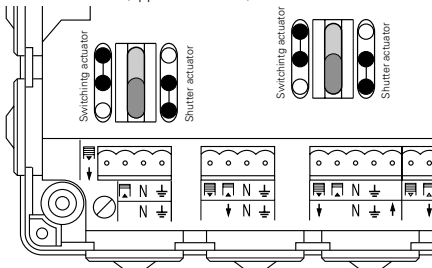

Fig. 2b: Location and positioning of the plug-in jumpers when the device is operated as a 2 x 2-gang shutter actuator (application V 3.1)

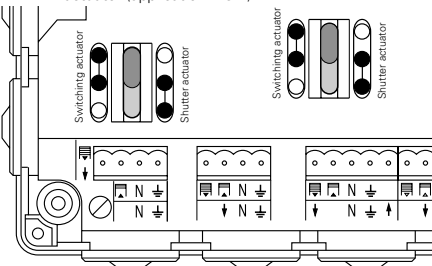
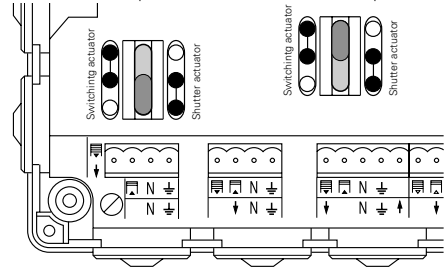

Fig. 2c: Location and positioning of the plug-in jumpers when the device is operated as a combined switching/shutter actuator.

The figure shows the positioning of the plug-in jumpers (for application V 2.1 (I in "switching actuator" position and II in "shutter actuator" position).



Note

For application V 2.2, the plug-in jumpers are repositioned accordingly (I in "shutter actuator" position and II in "switching actuator" position).

Device Description

General

The device is a combination of an EIB actuator and an EIB sensor. Both elements can be operated independently of each other on one EIB line.

The behaviour of the inputs (Fig. 1, Pos. 8) and the outputs (Fig. 1, Pos. 1 - 4) is defined (parameterized) via the EIB tool software (ETS).

The sensor inputs can control the outputs. Thus, e.g., the outputs can be controlled both via the EIB line and via the local control (conventional pushbutton switch).

For its operation, the combi actuator needs an external power supply of 230 V ~.

This 230 V power supply is also applied to the overcoupling terminal (cf. Fig. 1, Pos. 6) (looped-through internally). In this respect, please observe in any case the max. load capability (cf. "Technical Data").

The operating voltage and the contact interrogation voltages (optionally 24 V ~ or 230 V ~) are generated by the combi actuator.

The contact interrogation voltage can also be provided externally (24 V ~ or 24 V - or 230 V ~).

In this case, a polyphase operation is possible; **please read the "Important Information" chapter carefully.**

The sensor part

The inputs (Fig. 1, Pos. 8)) can be used as binary inputs to generate ON/OFF switching messages. By means of these messages, other EIB components can be operated via the EIB line.

Any edge modification may (upon an appropriate parameterization) trigger a bus message. In this case, it is parameterized via the ETS or the controller 6910-500 how a rising or falling edge is to be translated into a bus message.

It is possible to switch the binary inputs via extra-low-voltage switches (e.g. 24 V window contacts).

If the inputs (Fig. 1, Pos. 8) are used as extension inputs, the actuator outputs switch accordingly. Parallel to this, corresponding data is transmitted on the EIB line.

For 230 V applications, only pushbuttons (e.g. 2020 US) may be used as switching elements.

Where switches shall be used as operating elements, only 24 V ~ or 24 V - may be utilized.

The actuator part

The actuator element of the combi actuator receives messages via the EIB line and switching commands via the integrated inputs (either as binary inputs or extension control, depending on the parameterization). The actuator element converts these, depending on how it is parameterized (effected via the EIB tool software, ETS), into switching commands for its four outputs, or external receivers. In this way, electrical consumers (configuration as a switching actuator) can be switched on and off or up to 2 x 2 shutters or shutter groups (configuration as a shutter actuator) can be

Device Description

controlled. A mixed operation as a combined 2-gang switching and 1 x 2-gang shutter actuator is possible.

The use of the outputs is defined via the two plug-in jumpers I and II (cf. Fig. 1) on the device. This definition is made by pairs for the outputs 1/2 (with jumper I) and 3/4 (with jumper II).

The positioning of the plug-in jumpers for each intended use is printed on the inner cover. You can also find this information in the figures on pages 4, 5.

Use as a switching actuator

Apart from a simple ON/OFF switching function, the switch actuator fulfils the following functions, which can be parameterized via the ETS for each output:

- an adjustable switching delay (switch-on or switch-off delay or a staircase lighting function)
- logic operations (AND, OR)
- status function and status signal

Use as a shutter actuator

Two actuator outputs each (1/2 or 3/4) are forming one group. It is via these groups that the shutter control functions are transmitted to the shutter motors.

A wind-monitoring function can be parameterized via the ETS. This is effected in such a way that, in the case of wind alarm, the blinds or shutters will move to their upper end position.

As long as the wind alarm is active, the shutter control remains blocked (via the Powernet EIB bus and via local operating elements).

Control via the Powernet EIB bus is locked by means of a locking object, if its value = 1.

(Protection against an unwanted, automatic opening/closing).

Parameterization can be effected so that a blind or shutter actuated via EIB sensors moves to a preset position (object "Time move").

This permits e.g. that a shutter or a group of shutters can be moved to a predefined position via a light sensor.

Switching and shutter actuator

In this case, outputs 1/2 or 3/4 can be used for shutter control. The remaining outputs 3 and 4 or 1 and 2, resp., can be used as switching outputs for the enabling/disabling of electrical consumers (e.g. a room lighting).

When being used in this mixed operating mode, each half of the device keeps its full functionality.

Technical Data

Power supply

System voltage:	230 V ~ $\pm 10\%$, 50 Hz
Current consumption:	≤ 35 mA
Power supply unit for inputs:	18 ... 28 V ~, max. 50 mA

Switching capacity

2300 W/VA

Switching current

Shutter actuator: for single-phase operation:	max. per output: 5 A, $\cos \varphi = 0,5$ however total current max. 10 A distributed to all outputs; related to sup- ply terminals (Fig. 1, Pos. 5)
Switching actuator: for polyphase operation ($T_u \leq 30$ °C):	Observe ambient temperature T_u ! max. 3 x 10 A and 1 x 2 A, $\cos \varphi = 0,5$
for polyphase operation ($T_u \leq 45$ °C):	max. 3 x 6 A and 1 x 2 A, $\cos \varphi = 0,5$
for single-phase operation ($T_u \leq 35$ °C):	however total current max. 10 A distributed to all outputs; related to sup- ply terminals (Fig. 1, Pos. 5)

Derating curve

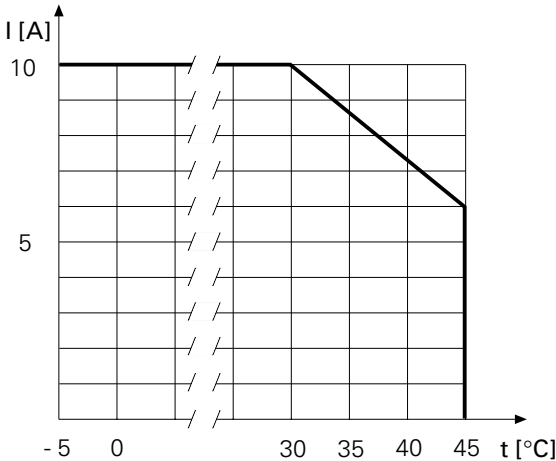

Technical Data

Connections	via screw/plug-in terminals with max. 2,5 mm ² line cross section
EIB:	2-pole screw/plug-in terminal (Fig. 1, Pos. 9)
Inputs:	6-pole screw/plug-in terminal (connections 3 - 6, Fig. 1, Pos. 8)
Contact interrogation:	24 V ~ (max. 50 mA) 6-pole screw/plug-in terminal (connections 1 and 2, Fig. 1, Pos. 8)
Extension/Contact interrogation:	230 V ~ (max. 1 A) 2-pole screw/plug-in terminal (Fig. 1, Pos. 7)
Switching outputs:	via screw/plug-in terminals (3 x 4- and 1 x 5-pole, Fig. 1, Pos. 1 - 4)
Supply input:	5-pole screw/plug-in terminal (Fig. 1, Pos. 5)
Supply overcoupling:	5-pole screw/plug-in terminal (Fig. 1, Pos. 6)
max. terminal load:	10 A (ref. to all L- and N- terminals)
Permitted line length	max. 100 m for binary inputs or extension operation
Operating and display elements	programming key PROG red programming LED
Degree of protection	IP 54
Ambient temperature	
Operation:	- 5 to + 45 °C
Storage and transport:	- 20 to + 70 °C
Housing dimensions	178 x 150 x 48 (L x W x H in mm)
Weight	0.95 kg

Internal Links

The following three figures illustrate the internal links of the outputs (cf. Fig. 1, Pos. 1 - 4) with the connections for the power supply (cf. Fig. 1, Pos. 5). These links are depending on the position of the plug-in jumpers, i. e. on the configuration of the combi actuator

- as a 4-gang switching actuator (cf. Fig. 2a and Fig. 3a),
- as a 2 x 2-gang shutter actuator (cf. Fig. 2b and Fig. 3b)
- or as a 2-gang switching/1 x 2-gang shutter actuator (cf. Fig. 2c and Fig. 3c).

ATTENTION

These internal links are significant in two respects!

- Depending on the configuration, the links of the inputs for the power supply (cf. Fig. 1, Pos. 5) with the actuator outputs vary.
- When the device is configured as a 4-gang switching actuator or as a 2-gang switching/1 x 2-gang shutter actuator, voltages are applied to certain outputs although the respective actuator output is set to the switching state OFF. This design inversion is a significant reason for the instruction that all screw/plug-in terminals (also those for unused outputs) must be clipped on. It is due to the fact that the relays at output 1 and 3 are used for the shutter control function UP/DOWN as well as for the switching function ON/OFF.

Fig. 3a: Internal links when used as a **4-gang switching actuator**

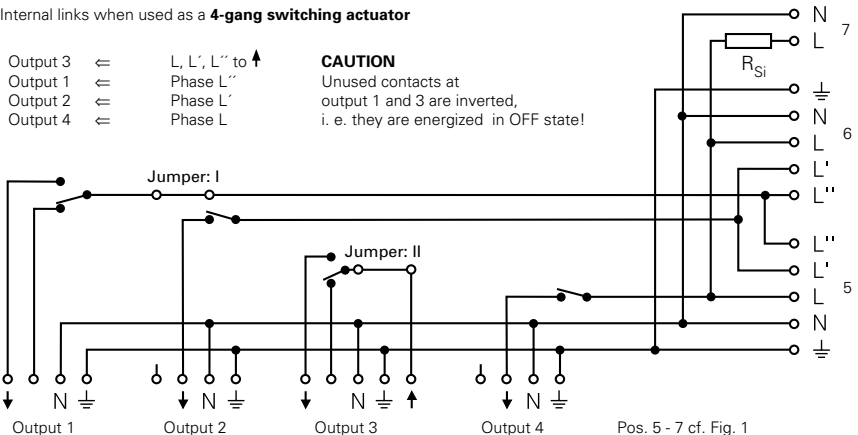

Internal Links

Fig. 3b: Internal links when used as a **2 x 2-gang shutter actuator**

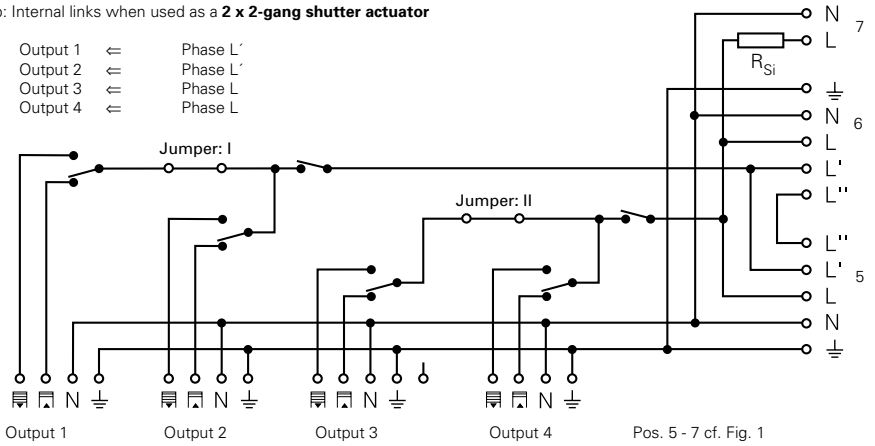
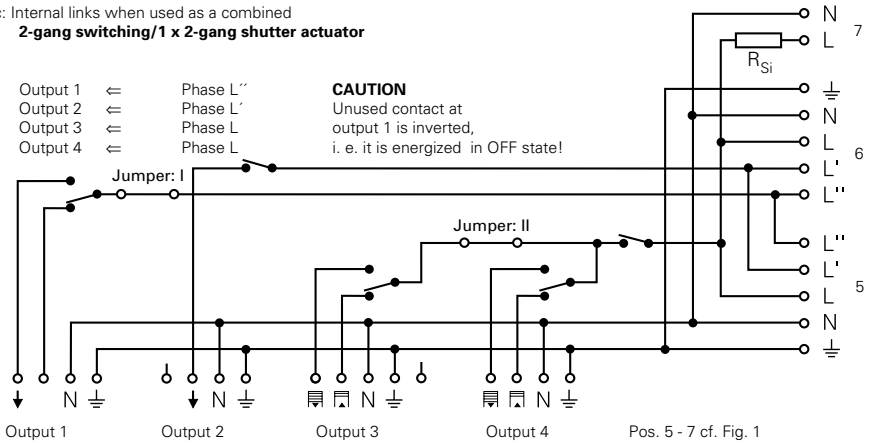

Fig. 3c: Internal links when used as a combined **2-gang switching/1 x 2-gang shutter actuator**



Example of Wiring as a 4-Gang Switching Actuator

NOTES

For the possible wiring of inputs (Fig. 1, Pos. 8), cf. pages 15 and 16.

In the example shown below, **only pushbuttons (e.g. 2020 US) are permitted!**

Linking of the inputs of the sensor part with the outputs of the actuator part:

- Input A ⇒ Output 1
- Input B ⇒ Output 2
- Input C ⇒ Output 3
- Input D ⇒ Output 4

Fig. 4a:

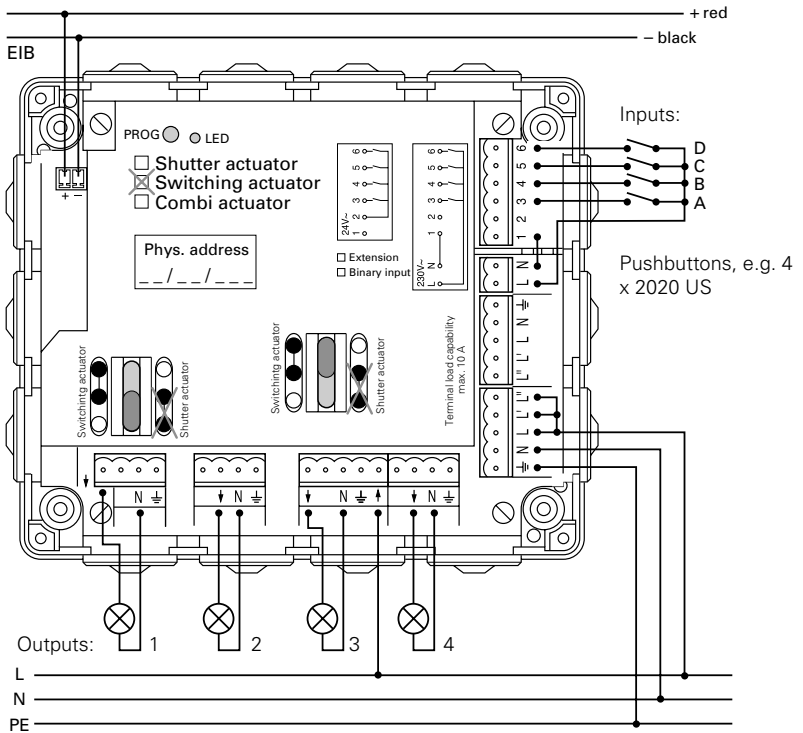

Example of Wiring as a 2 x 2-Gang Shutter Actuator

NOTES

For the possible wiring of inputs (Fig. 1, Pos. 8), cf. pages 14 and 15.

In the example shown below, only pushbuttons (e.g. 2020/4 US) are permitted!

Linking of the inputs of the sensor part with the outputs of the actuator part:

- Input A / B ⇒ Output 1 / 2 (shutter group 1)
- Input C / D ⇒ Output 3 / 4 (shutter group 2)

Fig. 4b:

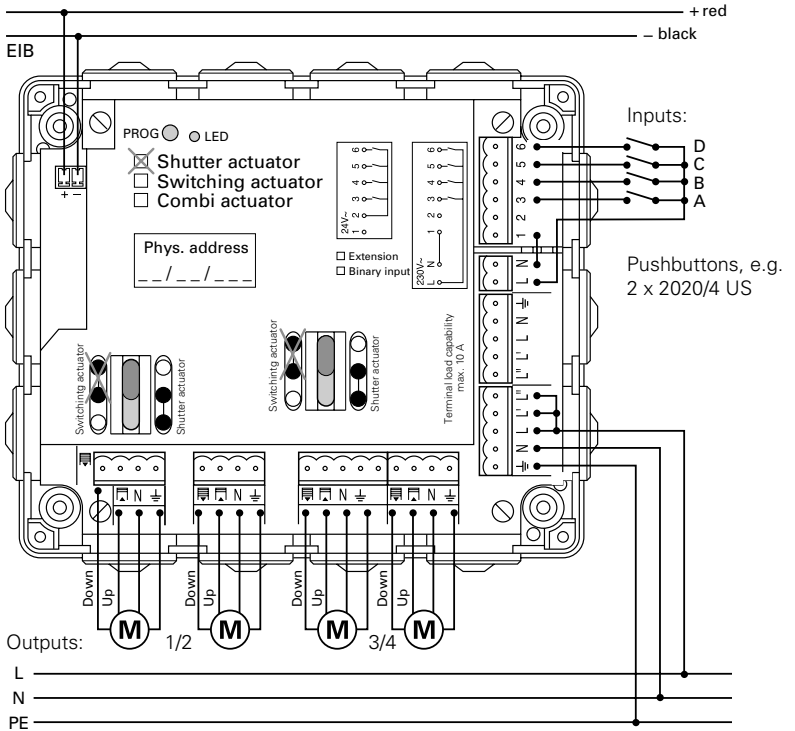

Wiring as a 2-Gang Switching/1 x 2-Gang Shutter Actuator

NOTES

For the possible wiring of inputs (Fig. 1, Pos. 8), cf. pages 15 and 16.

In the example shown below, **only pushbuttons (e.g. 2020 US and 2020/4 US) are permitted!**

Linking of the inputs of the sensor part with the outputs of the actuator part:

- Input A ⇒ Output 1
- Input B ⇒ Output 2
- Input C/D ⇒ Output 3/4 (shutter group)

Fig. 4c:

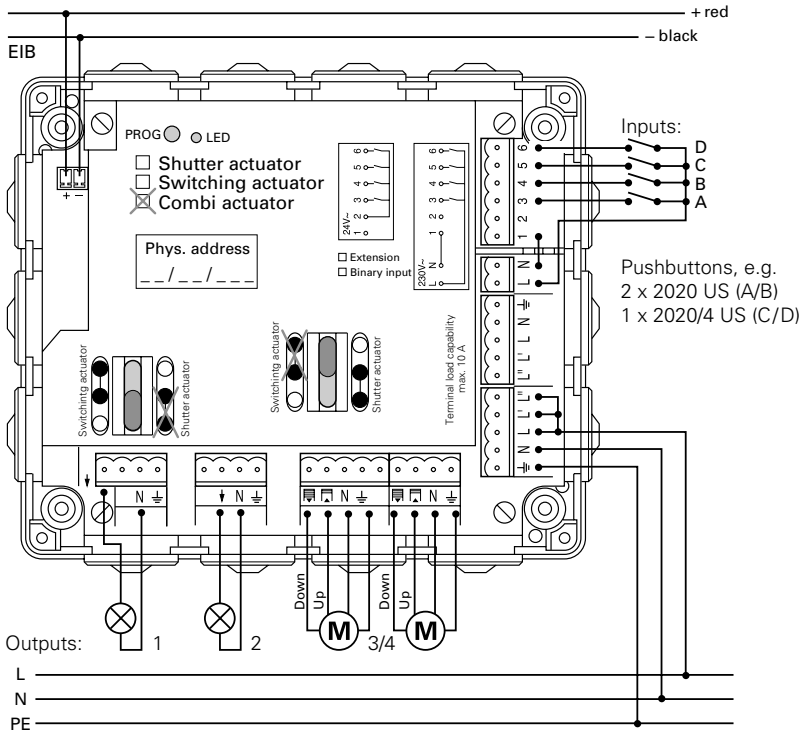

Wiring Diagrams for Inputs (230 V Interrogation Voltage)

The following figure shows the combi actuator connected to an *internal* 230 V power supply for contact interrogation.

Fig. 5: 230 V ~ (internal)

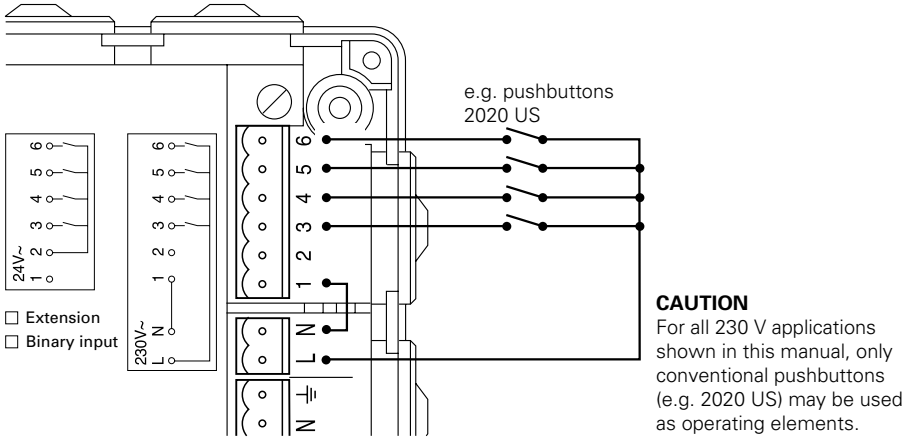

The following figure shows the combi actuator connected to an *external* 230 V power supply for contact interrogation.

The right figure 6b shows a wiring in polyphase operating mode. Please observe the national regulations referring to polyphase operation.

Fig. 6a: 230 V ~ (external single-phase operation)

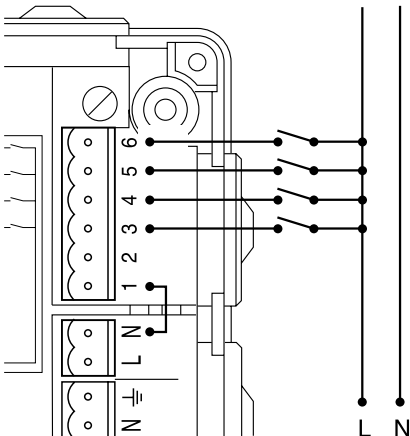
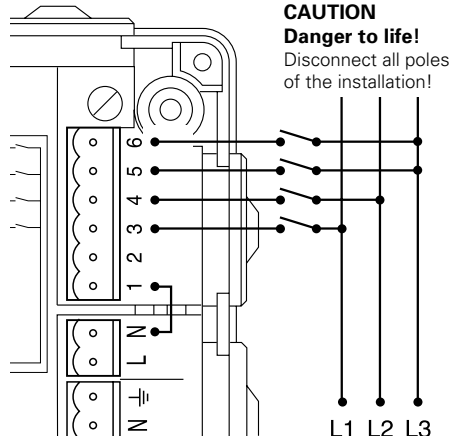

Fig. 6b: 230 V ~ (external polyphase operation)



Wiring Diagrams for Inputs (24 V Interrogation Voltage)

The following figure shows the combi actuator connected to an *internal* 24 V power supply for contact interrogation.

Fig. 7: 24 V ~/- (internal)

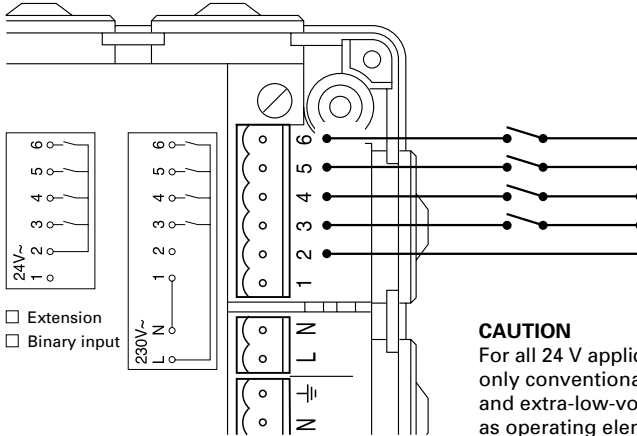

The following figure shows the combi actuator connected to an *external* 24 V power supply for contact interrogation. It is not necessary to take care of the polarity in this case.

Fig. 8: 24 V ~/- (external)

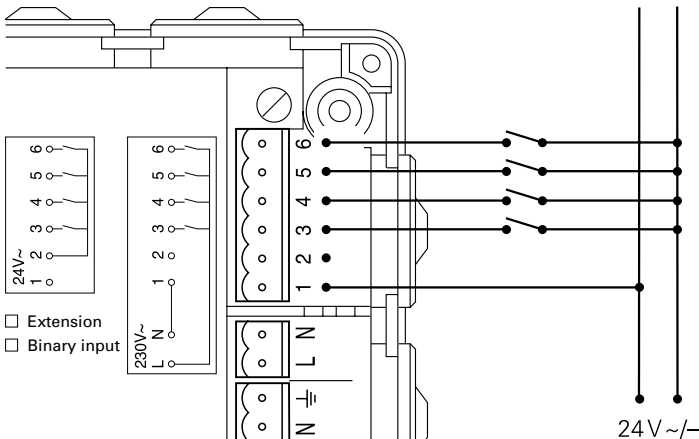

Installation

You should in any case read the "Important Information" chapter at the beginning of these operating instructions.

ATTENTION

De-energize all connection lines to be installed!

Take safety precautions against an unintentional energizing!

NOTE

Make sure which application has been provided for the combi actuator.

This allows you to draw conclusions with respect to:

- the wiring of the actuator outputs
- the placement of plug-in jumpers to define the function of the outputs
- the wiring of the sensor inputs
- parameterization
- the procedure upon commissioning.

Severe damage may occur, if the wiring of the outputs is not conforming with the use and the parameterization of the device!

NOTES

Make sure if the device is to be installed in a dry or a damp location. In damp locations, the combi actuator must not be installed on the ceiling.

In case of a wall installation, the water drain bore of the actuator housing must be located on the bottom (cf. the mounting position shown in Fig. 9)!

If the device is to be installed on an intermediate ceiling or in a cabinet, a sufficient cooling in conformity with the technical data has to be ensured.

ATTENTION

Commissioning must not be effected, unless

- all connections in conformity with the intended use have been laid, made and checked
- the plug-in jumpers have been inserted in those positions corresponding to the intended use of the outputs
- all screw/plug-in terminals, even the unwired ones, have been clipped on.

- Remove the housing cover of the combi actuator.

Inside of the housing, you will find the connections of the combi actuator and another cover. This inner cover remains in its position; during installation, there is no need to remove this cover.

- Mark the bore holes for fixing the housing (cf. Fig. 9).

The diameter of bores in the housing is 4.0 mm.

Fig. 9
Location/distance of bores for fixing the housing

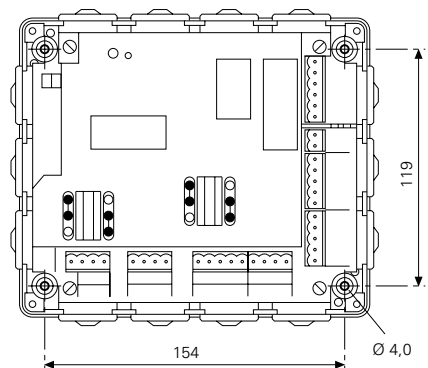

Installation

- For wall installation, pierce the drain opening positioned below on the rear side of the housing (for the mounting position shown in Fig. 9, cf. Fig. 10, Pos. E).

Fig. 10: Drain opening for wall installation

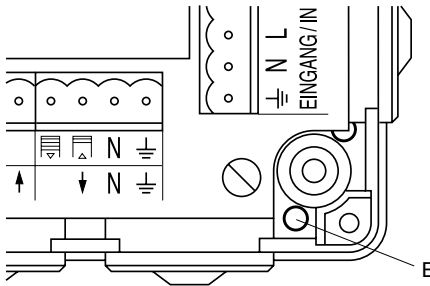

- Mount the combi actuator at the place provided.

NOTE

The connection of phase inputs L, L' and L'' required for single-phase operation can be implemented by means of jumpers. However, you may also use insulated strapping combs made by Wago-Kontakttechnik GmbH, P. O. box 2880 in D-32385 Minden (order No. 280-483).

- Unless you have done this already before, lay the connection lines now
 - for the sensor inputs (e.g. signalling contacts or pushbuttons for an optional local operation)
 - for the connected electrical consumers or shutter motors

NOTES

When using actuator outputs for a shutter control, the pushbuttons for the (optional) local operation must be designed as shutter pushbuttons.

Observe the national standards and regulations governing polyphase operation:

- if the voltage for contact interrogation is provided externally in polyphase operation;
- if the power supply of the actuator outputs is effected via several different phases.

ATTENTION

In case of single-phase operation with an external 230 V power supply, please connect the pushbuttons to the same phase as the power supply of the combi actuator.

NOTE

The web between the push-on terminal strip for the sensor inputs (cf. Pos. 8 in Fig. 1) and for the 230 V power supply (cf. Pos. 7 in Fig. 1) has been fitted for safety reasons. It separates the area of the sensor inputs in extra-low-voltage operation (24 V ~/-) from the area under 230 V system voltage.

If the contact interrogation voltage of 230 V ~ is to be provided by the combi actuator or externally, please connect the neutral conductor (terminal N) to terminal 1 on the push-on terminal strip for the sensor inputs (Pos. 8 in Fig. 1).

You must lead this connecting cable into the web through one of the recesses. Otherwise, the housing cover cannot be fastened properly.

The 230 V for contact interrogation are applied between the terminals L and N (cf. Pos. 7 in Fig. 1). This connecting line can be led out of the housing directly. You may also lay this line to the side with the sensor inputs through the second recess in the web and lead it out of the housing at this point.

Installation

- Assign the connecting line(s) of the terminal strip to the combi actuator.
- Before connecting the connecting line(s) to a screw/plug-in terminal, remove the damp-proof cable gland from the housing and slide it over the ends of the connecting line(s).
- Strip off approx. 7 mm of the insulation from the connecting line(s) and fix the bare cable ends in the provided contacts of the screw/plug-in terminal by screwing.

Up to this time the power supply must not be switched on!

ATTENTION

Thereby, observe the location and orientation of the pin names at the push-on terminal strips!

- Position the damp-proof cable gland at an appropriate distance from the screw/plug-in terminal and push terminal and cable gland into the provided recesses at the same time.

Ensure that no kinks are formed in the connecting lines.

ATTENTION

The screw/plug-in terminal **must** snap into place perceptibly in order to make a reliable connection.

Ensure that the screw/plug-in terminals are in a straight position in the lower part!

- After all connections have been made and checked, place the unused screw/plug-in terminals on the associated free locations (shock protection!).
- Close all unused housing openings by means of the supplied closed cable glands.
- Do not fix the housing cover unless a physical address has been assigned during commissioning.

Commissioning

ATTENTION

The preferred state of the output relay (in the case of failure or recovery of the bus voltage on the EIB line, or the voltage supply of the combi actuator) is set to OFF ex Works.

This preferred state can be set via the parameterizing software ETS.

If necessary, you will have to put the system in an operating state that precludes a dangerous, or unwanted, operating state when the voltage supply or the EIB line is switched on.

Physical address

- Fasten all covers (caps) prior to commissioning.

Operation of the device is software-dependent. To program, connect a PC, with ETS from version 2.1 onwards, to the EIB bus line by means of an EIB-RS 232 interface.

- **Switch on the voltage supply of the bus line.**



Do *not* switch on the supply voltage of the combi actuator!

NOTE

Programming key and LED are accessible, after the housing cover has been removed.

- Switch on the system voltage.
- Press the programming key on the device. The red programming LED illuminates.
- The red LED extinguishes after the physical address has been programmed.
- Note the number of the physical address on the device, if appropriate, using a non-smudge pen.
- Place the cover on the housing of the combi actuator and screw down.

Parameterization

Via the ETS, define the mode of operation of the inputs and outputs of the combi actuator and how the EIB messages are to be converted to control the outputs of the combi actuator.

Please refer to the current Technical Manual for a description of the available application versions and appurtenant parameters.

4-Gang Switching Actuator

ATTENTION

Ensure that all outputs (1 - 4) have been wired as switching outputs for electrical consumers.

NOTE

If necessary, you have to ensure prior to commissioning that the parameterization has been effected in compliance with the intended use of the combi actuator inputs and outputs.

- De-energize the combi actuator and the sensor inputs!
- Place both plug-in jumpers on the "switching actuator" location (cf. Fig. 2a on page 5 of these operating instructions or the names printed on the inner cover of the device).
- Continue commissioning as described on the next page under "Switch On".

2 x 2-Gang Shutter Actuator

ATTENTION

Ensure that both output pairs 1/2 and 3/4 have been wired as switching outputs for shutter control.

ATTENTION

Before the combi actuator can be taken into operation as a 2-gang shutter actuator, the limit switches of the shutters must have been set.

NOTE

If necessary, you have to ensure prior to commissioning that the parameterization has been effected in compliance with the intended use of the combi actuator inputs and outputs.

- De-energize the combi actuator and the sensor inputs.
- Place both plug-in jumpers on the "shutter actuator" position (cf. Fig. 2b on page 47 of these operating instructions or the names printed on the inner cover of the device).
- Continue commissioning as described on the next page under "Switch On".

Switching and Shutter Actuator

The combi actuator can be used in a mixed operating mode as a 2-gang switching and 1 x 2-gang shutter actuator.

ATTENTION

Ensure that the output pairs 1/2 and 3/4 have been wired in compliance with the desired mixed operating mode.

ATTENTION

Before outputs can be taken into operation as shutter actuator outputs, the limit switches of the shutters must have been set!

NOTE

If necessary, you have to ensure prior to commissioning that the parameterization has been effected in compliance with the intended use of the combi actuator inputs and outputs.

- De-energize the combi actuator and the sensor inputs.
- In accordance with the selected use of outputs 1/2 and 3/4, place the two plug-in jumpers on the "shutter actuator" or "switching actuator" location, resp.; cf. Fig. 2c (or the note ref. to Fig. 2c on page 5) in these operating instructions or the names printed on the inner cover of the device.
- Continue commissioning as described on the next page under "Switch On".

Switch On

ATTENTION

Before the power supply of the combi actuator and its sensor inputs is switched on again: consider the effects which the adjusted preferred states may have upon voltage recovery (e.g. an unwanted travelling of the shutter)!

- Switch on the power supply of the combi actuator. If an external power supply for the contact interrogation of the sensor inputs exists, switch it on, too.
- If you have installed a local operating element or a 24 V contact interrogation at the sensor inputs:
 - check if the connected electrical consumers are switched on and off properly.
- If shutter motors have been connected:
 - Check the movement direction of the shutters. If necessary, change the travelling direction of the shutter motors by reversing the connections "UP" and "DOWN" at the motors.
 - Check if the limit switches switch off the shutter motors properly.